

# DESCH Pex Couplings



PX 11 - GB

# Flexible DESCH Pex Couplings

The flexible DESCH Pex couplings are claw couplings with flexible elements to provide a torsionally flexible connection for shafts. The flexible elements excel in their wear resistance, ageing resistance and their temperature resistance from  $-30^{\circ}\text{C}$  to  $+80^{\circ}\text{C}$ . Thanks to their flexibility, impacts, rotary vibrations and noises are effectively absorbed. The flexible elements are dimensioned such that radial, axial and angular movements between the two halves of the coupling are cancelled out. The flexible DESCH Pex couplings are of the plug-in type for installation and do not involve any particularly rigorous requirements with respect to alignment accuracy. The balancing quality is, in accordance with DIN-ISO 1940, in the quality range G 16. DESCH Pex couplings can be used in the whole of machine construction wherever a reliable shaft connection is needed between motor and machine.

## Type B

The DESCH Pex type B coupling is fail-safe up to the fracture moment of the cast iron transmission cam and this provides maximum operational safety. The flexible elements can be supplied with hardness 80° shore A. With the fixed position of the flexible elements its deformability in axial direction is free, and so no damaging axial forces can act on the machine bearing even with alternating torque.

## Type A

The DESCH Pex type A coupling is manufactured in three-piece design. With the two-piece coupling (type B) it is possible to install packages after axial displacement of the drive engines or machines. With the three-piece coupling it is possible to install packages without axial displacement of the drive engine or machine.

## Selection

The torque of the machine  $T_{AN}$  is determined by:

$$T_{AN} [\text{Nm}] = 9550 \times \frac{P_{\text{Motor}} [\text{kW}]}{n [\text{rpm}]}$$

This torque  $T_{AN}$  multiplied by a safety factor „S“ depending on the application and the temperature factor  $S_T$  (see table page 5) gives the required nominal coupling torque  $T_{KN}$ .

$$\text{result: } T_{KN} \geq S \times S_T \times T_{AN}$$

## Wear indicator for DESCH Pex

The wear indicator for DESCH Pex couplings enables the condition of the flexible to be easily assessed. The wear condition can also be ascertained with the aid

of a stroboscope while the coupling is rotating.

The production process can thus continue undisturbed.

The wear indicator must be attached to the outside diameter of the coupling after the coupling has been fitted.



# DESCH Pex – Type A

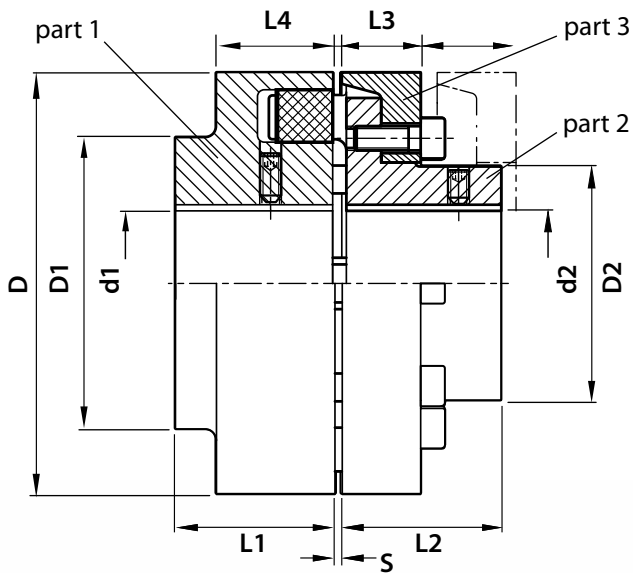
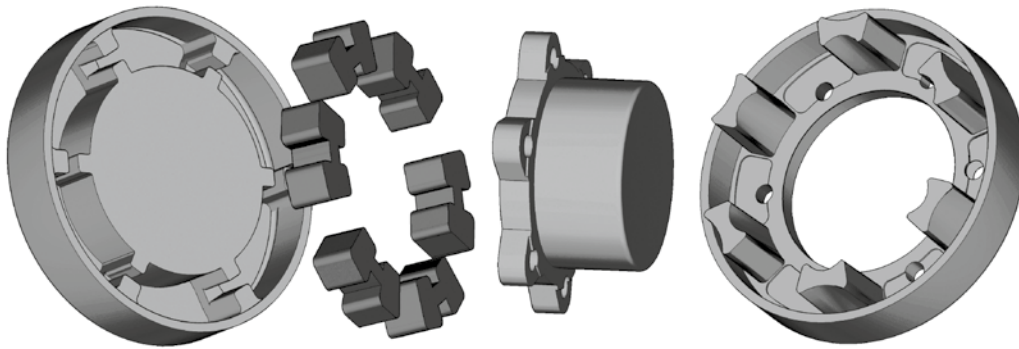

materials: coupling half EN-GJL-250  
flexible elements NBR 80° Shore A

## Type A

Size	Nominal torque Nm	Max. rotational speed rpm	Max. bore		D	L1	L2	D1	D2	L3	L4	S	Weight <sup>1)</sup> kg			Moments of inertia <sup>1)</sup> kgm <sup>2</sup>	Max. shaft misalignment at rotational speed n = 1500 rpm <sup>2)</sup>		
			d1	d2									Part 1	Part 2	Part 3		axiale ΔK <sub>s</sub> mm	radiale ΔK <sub>r</sub> mm	angular ΔK <sub>w</sub> °
110	160	5300	48	38	110	40	40	86	62	20	34	3	1,95	1,38	1,97	0,003	0,2	0,2	0,1
125	240	5100	55	45	125	50	50	100	75	23	36	3	3,05	2,42	1,97	0,005	0,25	0,25	0,1
140	360	4900	60	50	140	55	55	100	82	28	34	3	3,65	3,04	2,5	0,008	0,25	0,25	0,1
160	560	4250	65	58	160	60	60	108	95	28	39	4	5,05	4,19	3,49	0,014	0,3	0,3	0,1
180	880	3800	75	65	180	70	70	125	108	30	42	4	7,8	5,94	4,41	0,025	0,3	0,3	0,1
200	1340	3400	85	75	200	80	80	140	122	32	47	4	11	8,61	6,02	0,04	0,3	0,3	0,09
225	2000	3000	90	85	225	90	90	150	136	38	52	4	15	12,06	8,93	0,08	0,35	0,35	0,09
250	2800	2750	100	95	250	100	100	165	155	42	60	6	19,5	17,41	11,7	0,13	0,35	0,35	0,08

1) The information concerning weights and moments of mass inertia apply for medium holes.

2) The values mentioned are valid for 1500 rpm and may occur only seperately. At multiple misalignments or higher speeds the values must be reduced.

## DESCH Pex – Type B

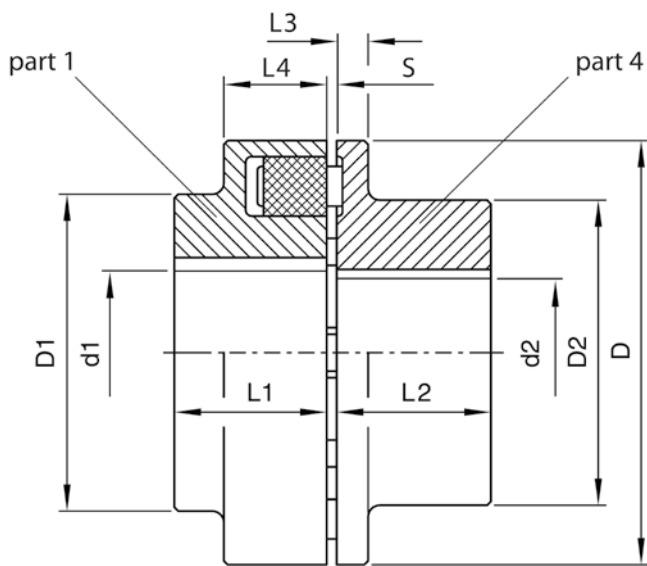
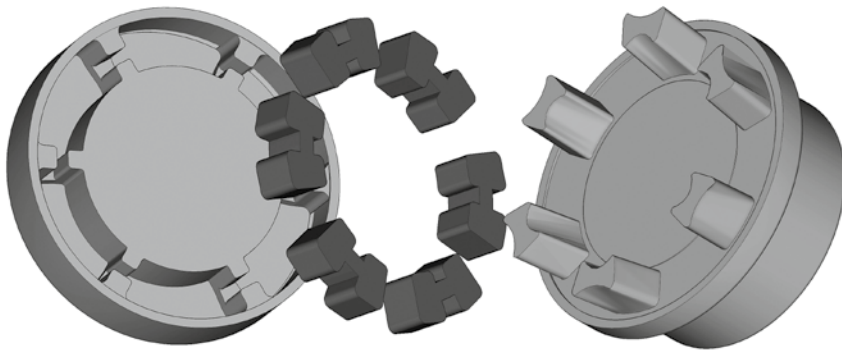

materials: coupling half EN-GJL-250  
flexible elements NBR 80° Shore A

### Type B

Size	Nominal torque Nm	Max. rotational speed rpm	Max. bore		D	L1	L2	D1	D2	L3	L4	S	Weight <sup>1)</sup> kg		Moments of inertia <sup>1)</sup> kgm <sup>2</sup>	Max. shaft misalignment at rotational speed $n = 1500 \text{ rpm}^{2)}$		
			d1	d2									Part 1	Part 4		axiale $\Delta K_a$ mm	radiale $\Delta K_r$ mm	angular $\Delta K_w$ °
58	19	7500	19	24	58	20	20	–	40	8	20	3	0,24	0,28	0,0001	0,2	0,2	0,15
68	34	7000	24	28	68	20	20	–	50	8	20	3	0,32	0,45	0,0002	0,2	0,2	0,15
80	60	6000	30	38	80	30	30	–	68	10	30	3	0,75	0,94	0,0006	0,2	0,2	0,12
95	100	5500	42	42	95	35	35	76	76	12	30	3	1,3	1,55	0,0013	0,2	0,2	0,12
110	160	5300	48	48	110	40	40	86	86	14	34	3	1,95	2,25	0,003	0,2	0,2	0,1
125	240	5100	55	55	125	50	50	100	100	18	36	3	3,05	3,6	0,006	0,25	0,25	0,1
140	360	4900	60	60	140	55	55	100	100	20	34	3	3,65	4,5	0,007	0,25	0,25	0,1
160	560	4250	65	65	160	60	60	108	108	20	39	4	5,05	5,95	0,01	0,3	0,3	0,1
180	880	3800	75	75	180	70	70	125	125	20	42	4	7,8	8,5	0,02	0,3	0,3	0,1
200	1340	3400	85	85	200	80	80	140	140	24	47	4	11	12,4	0,04	0,3	0,3	0,09
225	2000	3000	90	90	225	90	90	150	150	18	52	4	15	15,5	0,07	0,35	0,35	0,09
250	2800	2750	100	100	250	100	100	165	165	18	60	6	19,5	19,5	0,12	0,35	0,35	0,08

1) The information concerning weights and moments of mass inertia apply for medium holes.

2) The values mentioned are valid for 1500 rpm and may occur only separately. At multiple misalignments or higher speeds the values must be reduced.

## Safety factors "S"

### Assignment of load characteristics according to type of working machine

<b>DREDGERS</b>	<b>RUBBER MACHINERY</b>	<b>PUMPS</b>
S Bucket conveyor	S Extruders	S Piston pumps
S Landing gear (caterpillar)	M Calenders	G Centrifugal pumps (light liquids)
M Landing gear (rail)	S Kneading mill	M Centrifugal pumps (viscous liquids)
M Manoeuvring winches	M Mixers	S Plunger pumps
M Pumps	S Rolling mills	S Press pumps
S Impellers		
S Cutter heads	<b>WOOD WORKING MACHINES</b>	<b>STONE AND CLAY WORKING MACHINES</b>
M Slewing gear	S Barkers	S Crusher
	M Planing machines	S Rotary ovens
<b>GENERATORS, TRANSFORMERS</b>	G Wood working machines	S Hammer mills
M Frequency transformers	S Saw frames	S Ball mills
M Generators		S Tube mills
M Welding generators	<b>CRANES</b>	S Beater mills
	G Luffing gear block	S Brick presses
<b>CHEMICAL INDUSTRY</b>	S Travelling gear	
M Cooling drums	G Hoist gear	<b>TEXTILE MACHINES</b>
M Mixers	M Slewing gear	M Batchers
G Agitators (liquid material)	M Derricking jib gear	M Printing and dyeing machines
M Agitators (semi-liquid material)		M Tanning vats
M Drying drums	<b>PLASTIC INDUSTRY MACHINES</b>	M Willows
G Centrifuges (light)	M Extruders	M Looms
M Centrifuges (heavy)	M Calenders	
	M Mixers	<b>COMPRESSORS</b>
<b>OIL INDUSTRY</b>	M Crushers	S Piston compressors
M Pipeline pumps		M Turbo compressors
S Rotary drilling equipment	<b>METAL WORKING MACHINES</b>	
	M Plate bending machines	<b>METAL ROLLING MILLS</b>
<b>CONVEYORS</b>	S Plate straightening machines	S Plate shears
M Pit-head winches	S Hammers	M Manipulator for turning sheets
S Winding engines	S Metal planing machines	S Ingot pushers
M jointed-band conveyors	S Presses	S Ingot and slabbing-mill train
G Belt conveyors (bulk material)	M Shears	S Ingot handling machinery
M Belt conveyors (piece goods)	S Forging presses	M Wire drawing benches
M Band pocket conveyors	S Punch presses	S Descaling machines
M Chain conveyors	G Countershafts, line shafts	S Thin plate mills
M Circular conveyors	M Machine tools (main drives)	S Heavy and medium plate mills
M Load elevators	G Machine tools (auxiliary drives)	M Winding machines (strip and wire)
G Bucket conveyors for flour		S Cold rolling mills
M Passenger lifts	<b>FOOD INDUSTRY MACHINERY</b>	M Chain tractor
M Plate conveyors	G Bottling and container filling machines	S Billet shears
M Screw conveyors	M Kneading machines	M Cooling beds
M Ballast elevators	M Mash tubs	M Cross tractor
S Inclined hoists	G Packaging machines	M Roller tables (light)
M Steel belt conveyors	M Cane crushers	S Roller tables (heavy)
M Drag chain conveyors	M Cane cutters	M Roller straighteners
	S Cane mills	S Tube welding machines
<b>BLOWERS, VENTILATORS</b>	M Sugar beet cutters	M Trimming shears
M Rotary piston blowers	M Sugar beet washing machines	S Cropping shears
G Blowers (axial/radial)		S Continuous casting plant
M Cooling tower fans	<b>PAPER MACHINES</b>	M Rollers adjustment drive
M Induced draught fans	S Couches	S Manipulators
G Turbo blowers	S Glazing cylinders	
	M Pulper	<b>LAUNDRIES</b>
<b>BUILDING MACHINERY</b>	S Pulp grinders	M Tumblers
S Hoists	M Calenders	M Washing machines
G Concrete mixers	S Wet presses	
S Road construction machinery	S Willows	<b>WATER TREATMENT</b>
	S Suction presses	M Aerators
	S Suction rolls	M Screw pumps
	S Drying cylinders	

### Operating factor "S"

Driving machines	Load characteristics of the working machine		
	G	M	S
Electric motors, turbines, hydraulic motors	1	1,25	1,75
Piston machines 4 – 6 cylinders	1,25	1,5	2
Piston machines 1 – 3 cylinders	1,5	2	2,5

### Temperature factor "S<sub>T</sub>"

θ [°C]	S <sub>T</sub>
- 20 < θ < + 30	1,0
+ 30 < θ < + 40	1,2
+ 40 < θ < + 60	1,5
+ 60 < θ < + 80	1,8



**DESCH** Antriebstechnik GmbH & Co. KG

Postbox 14 40 | 59753 Arnsberg/Germany  
Kleinbahnstraße 21 | 59759 Arnsberg/Germany  
T +49 2932 300-0 | F +49 2932 300-899  
I [www.desch.de](http://www.desch.de) | E [info@desch.de](mailto:info@desch.de)

**DESCH** DPC GmbH & Co. KG  
Postbox 14 40  
59753 Arnsberg/Germany  
Kleinbahnstraße 21  
59759 Arnsberg/Germany  
T +49 2932 300-0  
F +49 2932 300-830  
I [www.desch.de](http://www.desch.de)  
E [info@desch.de](mailto:info@desch.de)

**DESCH** Canada Ltd.  
240 Shearson Crescent  
Cambridge, Ontario  
Canada N 1T 1J6  
T +1800 2631866  
+1519 6214560  
F +1519 6231169  
I [www.desch.de](http://www.desch.de)  
E [desch@desch.on.ca](mailto:desch@desch.on.ca)

**DESCH** Italia  
Drive Technology  
Ufficio di rappresentanza in Italia  
Via Cavriana, 3  
20134 Milano/Italy  
T +3902 7391280  
F +3902 7391281  
I [www.desch.de](http://www.desch.de)  
E [desch.italia@desch.de](mailto:desch.italia@desch.de)

**DESCH** China  
Machinery Sales (Shanghai) Ltd.  
Building Nr. 3  
No. 388 Minshen Road,  
Songjiang Industrial Zone  
201612 Shanghai/China  
T +86 21 6126-8061  
F +86 21 57655155  
I [www.desch.de](http://www.desch.de)  
E [desch.china@desch.de](mailto:desch.china@desch.de)