

KWO® MultiTex® Ring 2.0

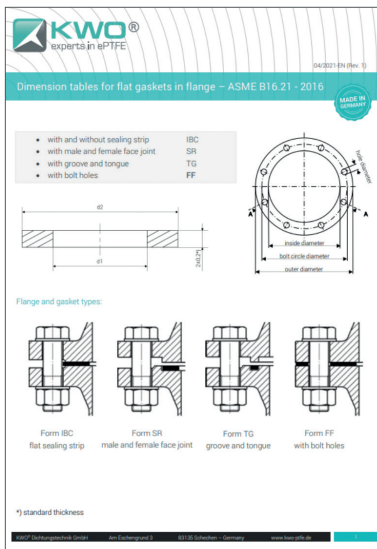

1. Select the correct size gasket to match the flange dimensions

Choose a gasket that matches the pressure class and nominal diameter of the standard flange:



Dimension tables for flat gaskets – ASME B16.21 – 2016

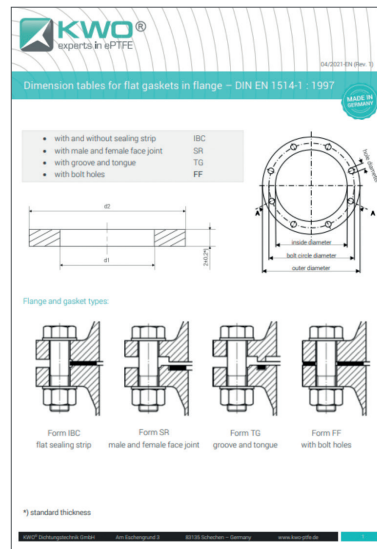

Dimension tables for flat gaskets – DIN EN 1514-1 : 1997

2. Determine Torque Value

To achieve a reliable seal, adequate gasket stress must be applied during installation. The tables provide an estimation of torque for use during assembly of pipe flanges.

Torque Guidelines

For reliable sealing of standardized flange connections. As a general rule, the highest possible surface pressure is essential to achieve a reliable seal. It must be ensured that both the maximum permissible surface pressure and the torque recommendation of the flange manufacturer are not exceeded. Our recommended torques in this respect are shown below for common flange types. It should also be noted that the user may have to provide proof of tightness and strength in accordance with EN1591-1.

The user is basically responsible for ensuring that the torques used do not exceed those of the pipeline manufacturer.

Nennweite	Torque [Nm]					Dichtungsdicke [mm]
	PN6	PN10	PN16	PN25	PN40	
10	30	30	50	50	50	1,5
15	30	50	50	50	50	1,5
20	30	50	50	50	50	1,5
25	30	50	50	50	50	1,5
32	50	120	120	120	120	1,5
40	50	120	120	120	120	1,5
50	50	120	120	120	120	1,5
65	50	120	120	120	120	1,5
80	120	120	120	120	120	1,5
100	120	120	120	230	230	1,5
125	120	120	120	420	420	1,5
150	120	230	230	420	420	1,5
200	120	230	230	420	440	1,5
250	120	230	420	440	440	1,5
300	230	230	420	440	440	1,5

Hinweis: Die oben angeführten Werte gelten nur unter folgenden Bedingungen:
 • Vorschweißflansch gemäß EN1092-1 Typ 11 Form B mit Dichtungen nach EN1514-1 Form IBC
 • Reibkoeffizient $\mu = 0,15$ (bei geschmierten Schrauben)
 • Schraubenqualität: 5.6 (Stahrschraube)

Torque Guidelines

3. Review and Follow Standard Bolted Flange Assembly Practices

KWO® Gasketing Products do not require special assembly practices. However, utilizing industry best practices is always recommended when assembling a bolted flange joint. Such practices have been developed by ASME, European Sealing Association (ESA), the Fluid Sealing Association (FSA) and the Association of German Engineers (VDI).

- ESA/FSA Gasket Installation Procedures Assuring Joint Integrity and Maximum Safety
- ASME PCC-1 Guidelines for Pressure Boundary Bolted Flange Joint Assembly
- VDI 2200 – Tight flange connections: Selection, calculation, design and assembly of bolted flange connections
- ASME also offers training classes on bolted flange joint assembly
- Multiple organizations also offer EN 1591-4 specified training content for bolted flange joint assembly

4. Torquing

1. Lubricate all connecting and fastening elements (screws, nuts and washers).

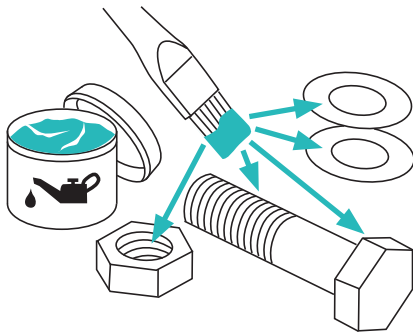

2. Align the gasket so that it is centered on the flange (use the screws as a guide).

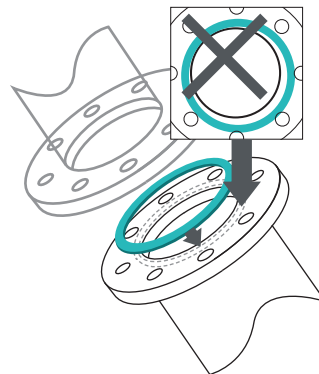

3. Install screws, nuts and washers on the flange.

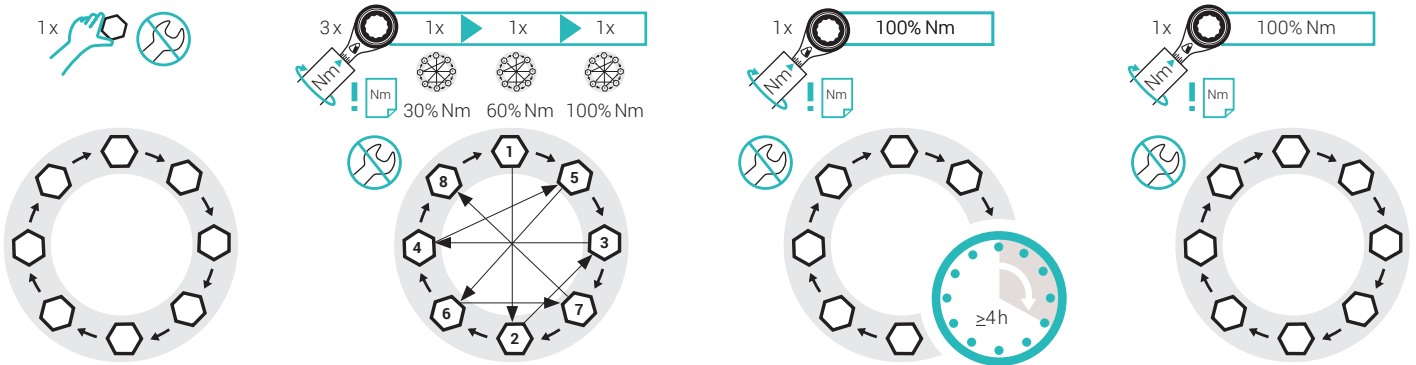
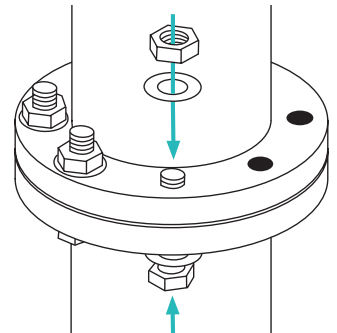

4. The screws are initially hand tightened in a sequential circular pattern.

5. Tighten the screws crosswise in three phases by using a calibrated torque:

- 1st pass: 30% of target torque
- 2nd pass: 60% of target torque
- 3rd pass: 100% of target torque

6. Tighten the screws crosswise with 100% of the torque and wait for 4 hours.

7. For final installation retighten the screws crosswise until the required torque is reached.

All technical information and advice given here is based on our previous experiences and/or test results. We give this information to the best of our knowledge, but assume no legal responsibility. Customers are asked to check the suitability and usability in the specific application, since the performance of the product can only be judged when all necessary operating data are available. Specifications are subject to change without notice. KWO's terms and conditions of sale apply to the purchase and sale of the product.

